

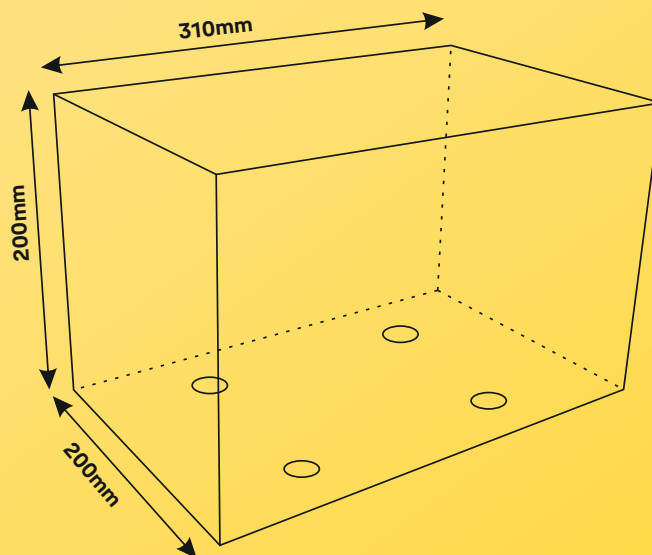

Trusted every day

YSPC 200

Cosmos Series Motorised Safe - Small



Exterior dimensions: 200(H) x 310 (W) x 200 (D)
Weight - 6.8 kg, Volume - 8.8 Liters

FEATURES & BENEFITS

- Total Peace of Mind
- Digital Solution
- Motorised Bolts
- Emergency Access
- Ease of Installation
- Secure
- Convenience
- Status Information
- Multiple Modes
- Service Assurance

STORES UP

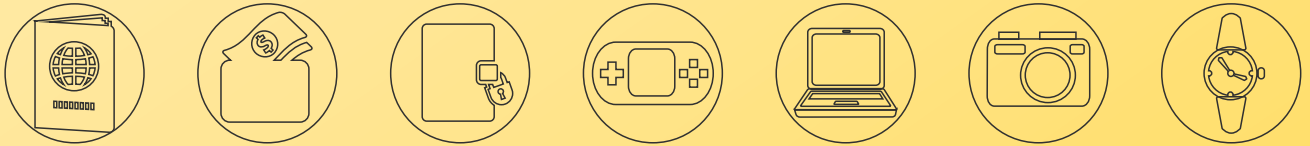

WARRANTY



This product has been designed and tested to meet strict Yale Performance Standards. Warranty against manufacturing faults for 1 year.

